



# Connect3<sup>®</sup> R 2-in-1 High-Back Booster

2-in-1 High-Back Booster Instruction Manual

**40–120 lb (18–54 kg)**

**38–63 in (97–160 cm)**

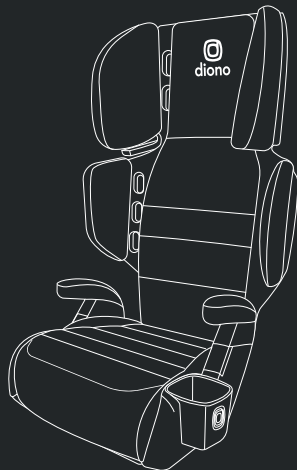

**READ INSTRUCTION MANUAL**  
before using this child restraint

## WE LOVE TO HELP

**Hello there, welcome to the Diono® family!** We've created this lovingly engineered car seat to help keep your child comfortable and safe with all of the goods and none of the gimmicks.



**Any questions?**  
**Diono U.S.: 1-855-463-4666**

# CONTENTS

<b>Registration</b>	<b>5</b>
<b>Car Seat Use After A Collision</b>	<b>6</b>
<b>Warning</b>	<b>7-11</b>
<b>Parts</b>	<b>12</b>
<b>Vehicle Seat Belt Types</b>	<b>13-14</b>
<b>Vehicle Seating Locations</b>	<b>15</b>
<b>First Setup</b>	<b>16-18</b>
A. Attaching the Armrest	
B. Attaching and Removing the Backrest	
C. Adjusting the Recline Angle	
<b>Securing The Child</b>	<b>19-25</b>
Using the backless shoulder belt guide strap	
<b>Cover</b>	<b>26-28</b>
<b>Cup Holder</b>	<b>29</b>
<b>Care &amp; Maintenance</b>	<b>30</b>
<b>Warranty</b>	<b>31-33</b>

## OUR STORY

Diono® is proud to be Made of Seattle®, a city known for its pioneering spirit. We were born from a commitment to innovation and safety that began in 1999. Seattle's unique culture inspired us then, and continues to drive us today as we design revolutionary products that protect growing families and solve the challenges of a busy backseat.

Our passion for problem-solving has inspired us to create several groundbreaking industry firsts: Radian®, the original 3-across all-in-one convertible car seat; Monterey®, the original expandable booster seat; and now Connect3®, the first and only booster that fits 3-across.

Our dedication to world-class engineering and technical innovation means that whether you're on the road, out for a walk, or on-the-go with Diono®, you can trust us to keep your family safe. We are honored that parents have been trusting us with their most precious cargo for over 25 years.

Today, over a million children travel safely in a Diono® car seat every day. We're here to help you unlock the #JoyOfTheJourney, every step of the way.



## REGISTER THIS BOOSTER

Please take a few moments to promptly fill out and return the attached card or register online using the direct link to the manufacturer's registration website provided.

Child restraints could be recalled for safety reasons. You must register this restraint to be reached in a recall. Send your name, address, e-mail address if available, and the restraint's model number and manufacturing date to:

**Diono U.S., PO Box 77129, Seattle, WA 98177** or call 1-855-463-4666 or register online at:  
<http://www.diono.com/product-registration/>



For recall information, call the U.S. Government's Vehicle Safety Hotline at 1-888-327-4236 (TTY: 1-800-424-9153), or go to <http://www.NHTSA.gov>.

For future reference, in the case of a change of address, please take a moment to fill out the following information:

**Model Number:**

**Manufacture Date:**

This information can be found either on the registration card or on the manufacturing label located on the seat.

# CAR SEAT USE AFTER A COLLISION

## UNITED STATES

The U.S. National Highway Traffic Safety Administration (NHTSA) recommends that car seats be replaced following a **MODERATE** or **SEVERE** collision in order to ensure a continued high level of collision protection for child passengers. In the U.S., car seats do not automatically need to be replaced following a **MINOR** collision.

**NHTSA defines a MINOR crash as one in which ALL of the following apply:**

- The vehicle was able to be driven away from the crash site.
- The vehicle door nearest the car seat was not damaged.
- None of the passengers in the vehicle sustained any injuries in the crash.
- If the vehicle has air bags, the air bags did not deploy during the crash; **and**
- There is no visible damage to the car seat.

**NEVER use a car seat that has been involved in a MODERATE or SEVERE collision.**

**⚠️ WARNING! DEATH or SERIOUS INJURY can occur! ⚠️**



**Never place this child restraint in a vehicle seating location with an active front air bag. Death or serious injury may occur.** If an air bag inflates, it can hit the child or child restraint with enough force to cause serious injury or death to your child. For vehicles with side passenger air bags, refer to your vehicle owner's manual for information on your child restraint installation.

- ▶ **Use only the vehicle's lap and shoulder belt system to restrain the child in this booster seat.**

#### **EXPIRATION**

- **DO NOT** use the child restraint if any part is damaged or broken, expired (over eight years from date of purchase), missing instructions, missing parts, or if the straps are cut, frayed, or damaged in any way. For any questions or concerns or to find out if the damaged part(s) can be replaced, contact Diono® at:

**Diono® U.S.:** 1-855-463-4666 or online at [www.Diono.com](http://www.Diono.com)

**⚠️ WARNING! DEATH or SERIOUS INJURY can occur! ⚠️**

**SAFE PRACTICES**

- **WARNING!** Use **ONLY** the vehicle's lap and shoulder belt system when restraining the child in this booster seat. **DO NOT** use a lap belt only!



- In backless mode, use **ONLY** with children whose ears are below the top of the fully raised vehicle seat or headrest.





**⚠️ WARNING! DEATH or SERIOUS INJURY can occur! ⚠️**

- Use **ONLY** with children who weigh 40–120 lb (18–54 kg) **AND** whose height is 38–63 in (97–160 cm).
- **DO NOT** leave loose objects, such as books, bags, etc., in the back of the vehicle. In the event of a sharp turn, sudden stop, or collision, loose objects can be thrown around and possibly cause serious injury to vehicle occupants.
- **ALWAYS** check all surfaces of restraint before securing your child. In warm weather, child restraints can become very hot. Do not allow children to play with vehicle seat belts.
- Follow all instructions on the child restraint and in the vehicle's owner's manual.
- Before installing this child restraint in a vehicle, be sure to also check the vehicle owner's manual for information on proper installation.
- **DO NOT** use child restraint in any configuration not shown in the instructions.
- **ALWAYS** make sure the vehicle seat belt can properly retract before each use.



 **WARNING! DEATH or SERIOUS INJURY can occur!** 

- **NEVER** leave your child unattended.
- **NEVER** install in a rear-facing or side-facing vehicle seat or on the back of a folded down vehicle seat.
- **ALWAYS** install this child restraint in a rear vehicle seat whenever possible.
- **DO NOT** use this child restraint with any other backrest or cushions.
- **ALWAYS** secure the child restraint using the vehicle seat belt even when it is unoccupied. It could injure other occupants in a sudden stop or collision.
- **DO NOT** use any accessories, inserts or products not included with this child restraint, unless approved by Diono®. Items not tested with this child restraint could injure your child.
- **DO NOT** modify your child restraint.
- **NEVER** provide this child restraint to another person without also providing them with the instruction manual.

 **WARNING! DEATH or SERIOUS INJURY can occur!** 

## CERTIFICATION



This child restraint system conforms to all applicable requirements of U.S. Federal Motor Vehicle Safety Standards (FMVSS) 213 and is certified for use in passenger cars, multi-purpose passenger vehicles, and trucks only.



**THIS RESTRAINT IS NOT CERTIFIED FOR USE IN AIRCRAFT.** Aircraft seats do not have shoulder belts which are required for use with this child restraint.

## PARTS

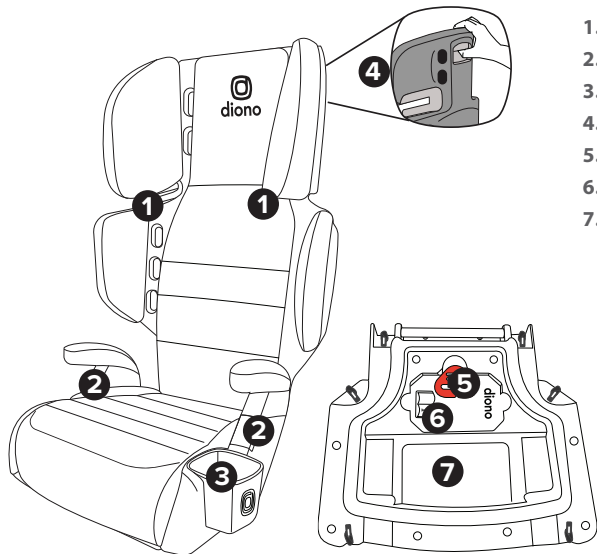

1. Shoulder Belt Guides
2. Lap Belt Guides
3. Cup Holder
4. Headrest & Backrest Height Adjuster
5. Backless Shoulder Belt Guide Strap
6. Instruction Manual Storage
7. Cup Holder Storage

## VEHICLE SEAT BELT TYPES

The following types of vehicle belts **CANNOT BE USED** with your child restraint.

If any of the belt types listed below are in the chosen seating position, you **MUST** choose another seating position.

1. Motorized (Automatic) Vehicle Belts
2. Dual Retractor Lap/Shoulder Belts
3. Lap Belt Only
4. Inflatable Seat Belts
5. Door Mounted Vehicle Belts

*Please refer to your vehicle owner's manual for specific information about seat belts and their use with child restraints.*

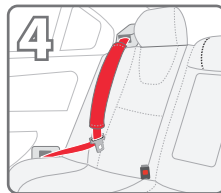
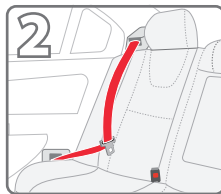
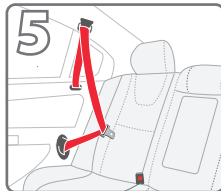
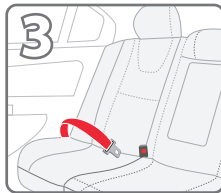
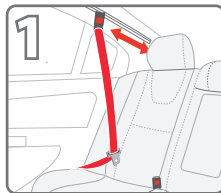

## VEHICLE SEAT BELT TYPES

**WARNING!** Use **ONLY** the vehicle's lap and shoulder belt system when restraining the child in this booster seat. **DO NOT use a lap belt only! This could result in serious injury or death.**

### TYPES OF RETRACTORS

Please consult your vehicle owner's manual to determine the type of retractor in use.

#### 1. Emergency Locking Retractor (ELR)

- Only locks with sudden stops, accelerations, turns or if involved in an accident.

#### 2. Automatic Locking Retractor (ALR)

- Found in older vehicles.

#### 3. Switchable Retractor

Most common type of retractor and is switchable from (ELR) to (ALR).

- Leave in **ELR** mode for **booster** use.

## VEHICLE SEATING LOCATIONS

According to accident statistics, children are safer when properly restrained in the rear seating positions than in the front seating positions. The safest seating position is one that works best for your specific child restraint, family and vehicle model.

If the child restraint does not install best in the rear center seating location, it is recommended to move to one of the outboard seating positions.

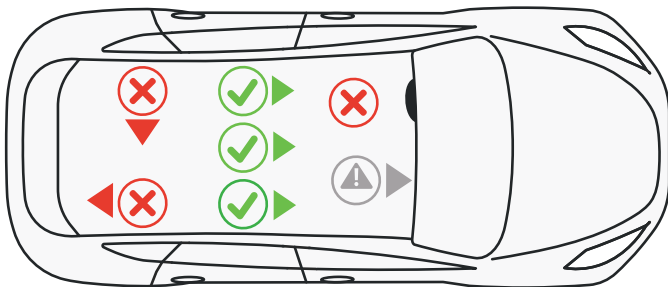

# FIRST SETUP

## A. ATTACHING THE ARMREST

1. Insert each armrest into the slots located on the seat base.
  - ***Make sure that the waffle pattern is facing outwards on each armrest.***
2. Listen for an audible “**click**” and lift up on the armrest to confirm they are locked into place.

***IMPORTANT: Once the armrest are attached they can not be removed.***

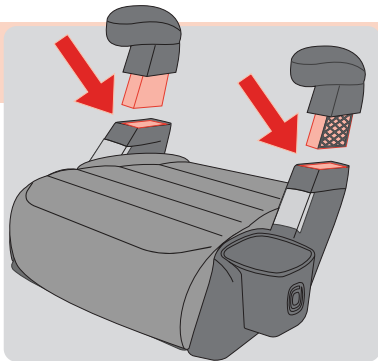



## FIRST SETUP

### B. ATTACHING THE BACKREST

1. With seat lying flat on the floor, place the backrest hook at the seat bottom and attach the backrest hook to seat mounting bar.
2. Push down on backrest just above the hook until fully engaged.
3. Rotate backrest to an upright position while maintaining pressure just above the hook.

***To detach the backrest, lay seat flat on it's back then rotate seat base so that the seat is laying completely flat. Next, pull up to unhook back rest from seat bottom.***

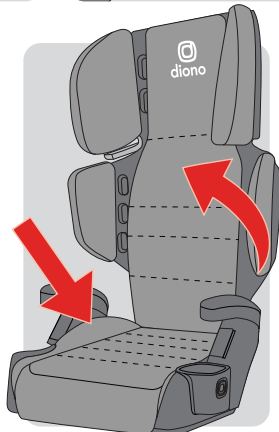
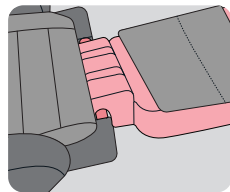
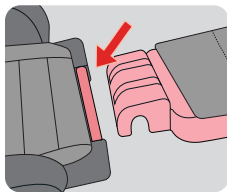

## FIRST SETUP

### C. ADJUSTING THE RECLINE ANGLE

**IMPORTANT:** It may also be necessary to adjust the recline angle of the booster seat to match that of the vehicle seat.

This booster seat features a two-stage recline angle that can adjust to match that of the vehicle seat:

1. **Push on the backrest of the booster seat until it moves and engages into the second recline position.**
2. **Push the booster seat bottom down and the backrest of booster seat back into vehicle seat until there is secure positioning.** A gap is acceptable as long as the head support is touching the vehicle seat back or headrest.

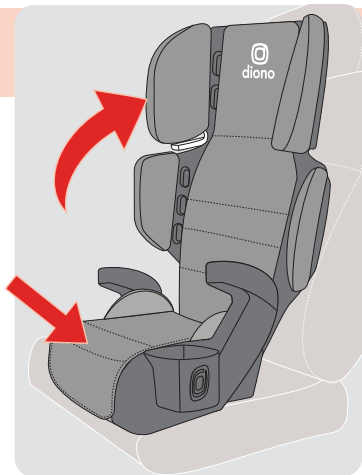

## SECURING THE CHILD

Use **ONLY** the vehicle's lap and shoulder belt system when restraining the child in this booster seat. **DO NOT** use a lap belt only!

**ALWAYS** make sure the vehicle seat belt can properly retract before each use.

- 1. Properly position child into installed seat.** The child should be sitting upright and seated all the way back in the booster seat.
- 2. Adjust head support to proper height.** Grip the headrest & backrest height adjuster lever and move up or down to the proper height for your child. The shoulder belt guide should be slightly above the child's shoulders (at least 1 cm).

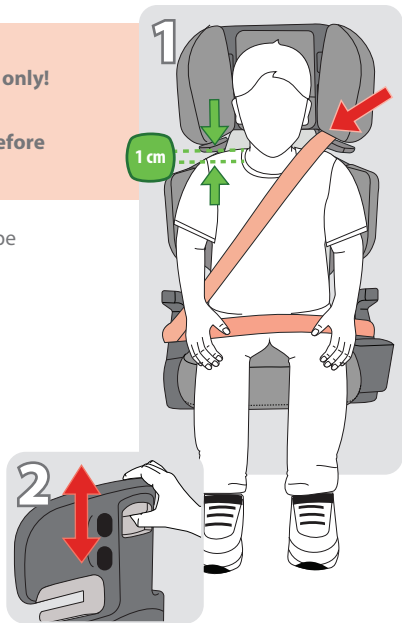

## SECURING THE CHILD

3. **Feed the shoulder belt portion of the vehicle seat belt through the shoulder belt guide.**

### IMPORTANT:

- When the shoulder belt is routed through the shoulder belt guide, pull some webbing out of the retractor. Slowly release it to make sure the belt properly feeds back into the retractor. **Do this between each use.**
  - **The vehicle shoulder belt should lay flat across the shoulder and should NOT be touching the child's neck.**
  - **NEVER lock the seatbelt retractor. Please refer to vehicle owner's manual for seat belt retractor information**
4. **Fasten vehicle seat belt across child.** The lap portion of the seat belt should rest within both lap belt guides. Make sure the vehicle seat belt is not twisted and lays flat across child's hips, torso and shoulder. **DO NOT** lay belt high over the child's belly.

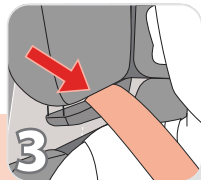

## SECURING THE CHILD

5. **Tighten the seat belt by pulling the shoulder belt portion upwards.**
6. **Confirm seat belt buckle is in correct position.** It should align with the belt path guides on the side of seat.



### INCORRECT SEAT BELT BUCKLE POSITION

**IMPORTANT:** After booster seat is installed and seat belt is fastened around child, it is important to confirm correct seat belt buckle position to ensure secure installation.

- **DO NOT position the vehicle shoulder belt over the armrest. It MUST pass through the lap belt guide.**
- **If the buckle is being pulled across the lap belt guide and into the seat, choose another seating position within the vehicle.**

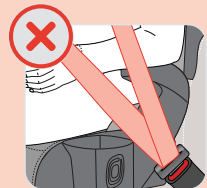

# SECURING THE CHILD

## BACKLESS BOOSTER



**WARNING!** Use **ONLY** the vehicle's lap and shoulder belt system when restraining the child in this booster seat. **DO NOT** use a lap belt only!

**WARNING!** **ONLY** use with children whose ears are below the top of the vehicle seat or headrest.

1. Remove the backrest.
2. Fold the backrest insert under the cover of the seat bottom.

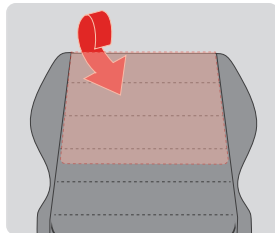
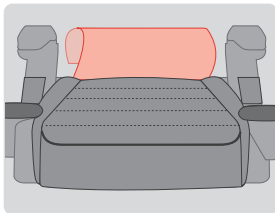

## SECURING THE CHILD

- 3. The booster seat should rest firmly on vehicle seat bottom and touching the vehicle seat back.** The entire seat bottom should sit flat on the vehicle seat.
- 4. Fasten vehicle seat belt across child.** The lap portion of the seat belt should rest within both lap belt guides. Make sure the vehicle seat belt is not twisted and lays flat across child's hips, torso and shoulder.
  - **DO NOT** lay belt high over the child's belly.
  - **The vehicle shoulder belt should lay flat across the shoulder and should NOT be touching the child's neck.**
- 5. Tighten the seat belt by pulling the shoulder belt portion upwards.**
- 6. Confirm seat belt buckle is in correct position.** It should align with the **RED** belt path guides on the side of seat.

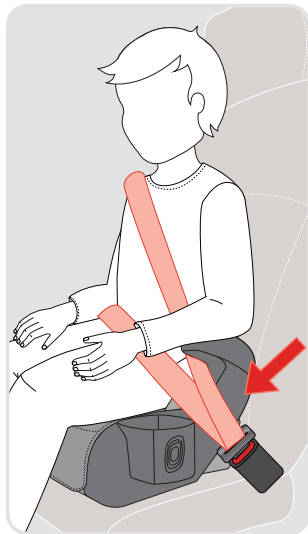

## SECURING THE CHILD

### INCORRECT SEAT BELT BUCKLE POSITION

**IMPORTANT:** After booster seat is installed and seat belt is fastened around child, it is important to confirm correct seat belt buckle position to ensure secure installation.

- **DO NOT** position the vehicle shoulder belt over the armrest. It **MUST** pass through the lap belt guide.
- If the buckle is being pulled across the lap belt guide and into the seat, choose another seating position within the vehicle.

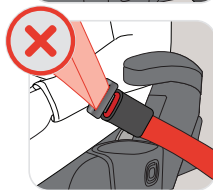
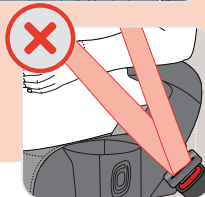
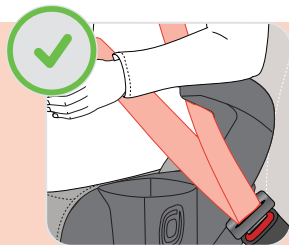



# SECURING THE CHILD

## USING THE BACKLESS SHOULDER BELT GUIDE STRAP

**WARNING!** In backless mode, if the vehicle shoulder belt does not correctly fit the child, then the seat must be used with the shoulder belt guide strap.

1. Remove shoulder belt guide strap from storage area underneath seat. Feed belt between the bar located on the seat base.
2. Position child correctly in seat, making sure lap and shoulder belts are positioned properly across child.
3. Attach the RED shoulder belt guide strap onto the diagonal shoulder belt.
4. Adjust strap to correct length, so that the RED guide is just above shoulder. The vehicle shoulder belt should lay flat across the shoulder and should NOT be touching the child's neck.

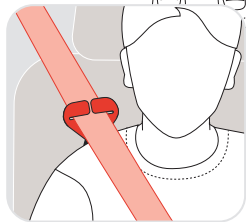
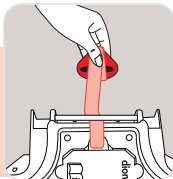

## COVER

- ▶ *Before removal or installation, have your phone handy to take photos of the process for future reference.*

### BACKREST AND BOTTOM SEAT COVER REMOVAL AND INSTALLATION

- To remove, pull the elastic loops over the tabs located around the shell of the booster seat. Remove the plastic tab from the top of the headrest.
- To install, insert the plastic tab into the gutter located on the top of the headrest. Then secure the elastic loops over the tabs around the shell.

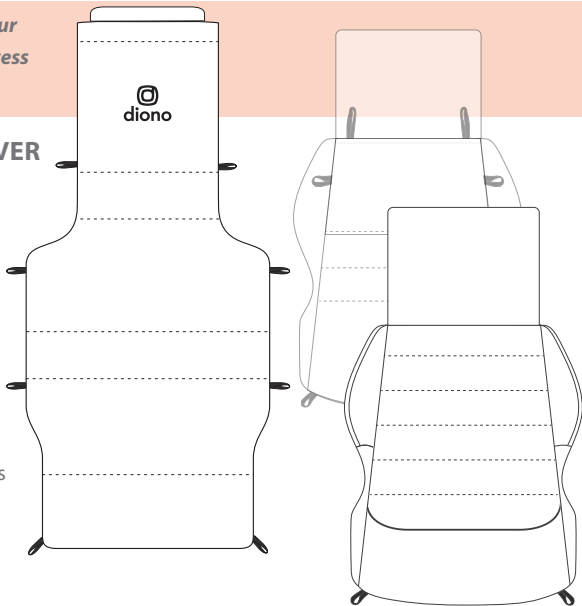

## COVER

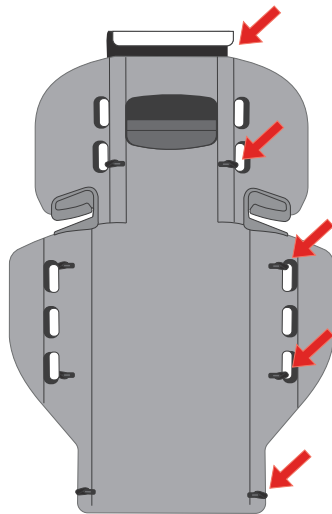
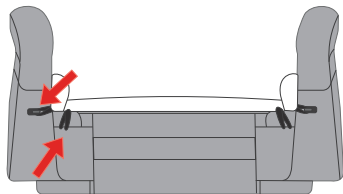
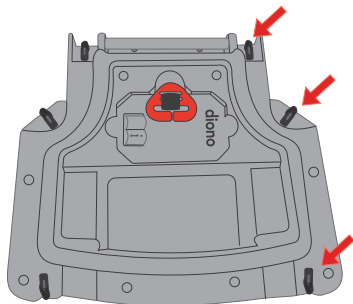

## COVER

### SIDE-WING COVER REMOVAL AND INSTALLATION

- To remove, gently pull the covers over the side-wing pods.
  - ▶ ***Do not pull off foam pads.***
- To install, gently position the covers over the side-wing pods. Make sure the covers are fully covering the pods and securely attached.
- ▶ ***Ensure the cover is completely attached before securing the child.***

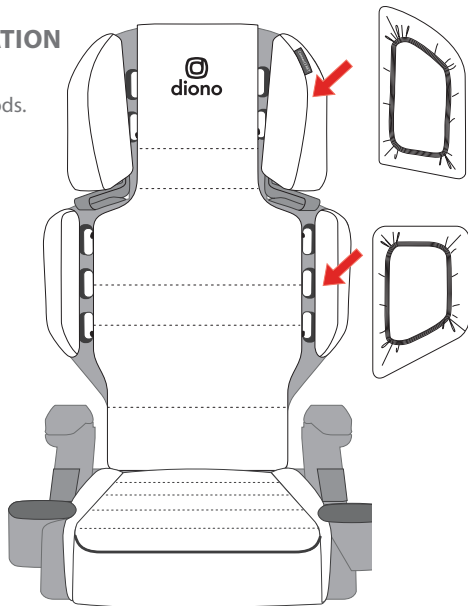

## CUP HOLDER

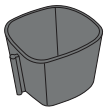

This booster seat features an easy to install slide-in and slide-out cup holder.

- To install, slide the T-shaped bracket on the cup holder into the T-shaped slot on the booster seat and press down.

**Always** check to make sure the cup holder is secure and pushed all the way down into the T-shaped slot on the booster seat. In the event of a sharp turn, sudden stop, or collision, loose objects can be thrown around and possibly cause serious injury to vehicle occupants.

**WARNING: DO NOT use with hot liquids and foods as this could burn a child.**

**IMPORTANT: DO NOT** step on or put excess weight on the cup holder which could cause it to break.

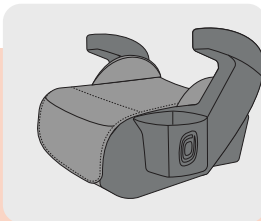
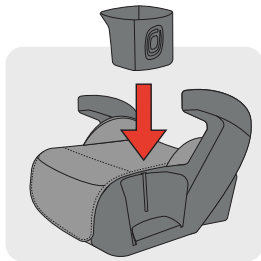

## CARE & MAINTENANCE

- **DO NOT use solvents, harsh detergents or any other chemical or cleaning agent. DO NOT lubricate any part of the seat.**
- **Remove seat cushion prior to washing. Do not wash seat foam.**

### CLEANING FABRICS: SEAT COVER

Machine wash separately in cold water on gentle cycle with mild detergent or hand wash fabrics in cold water. Dry flat and away from direct sunlight before re-use or storage. **DO NOT bleach, iron or dry clean.**



### CLEANING PLASTICS: SEAT SHELL AND COMPONENTS

Spot clean using a damp cloth and warm water with mild detergent. Towel dry completely before re-use or storage. **DO NOT bleach.**



# WARRANTY

As a part of this Diono Warranty Policy (Policy), Diono, L.L.C. dba Diono, a Washington limited liability company (Diono U.S.A.), and its foreign-related companies, Diono ULC, a Canadian unlimited liability company (Diono Canada), Diono Ltd. a United Kingdom limited company (Diono U.K.), and Diono GmbH, a German company with limited liability (Diono E.U.) (Diono U.S.A., Diono Canada, Diono U.K., and Diono E.U. shall be collectively referred to herein as Diono), warrants its products, namely its car seats, strollers, baby carriers, and accessories thereto (collectively, the Products) to their non-merchant original retail Product purchasers (collectively, the Purchasers) as follows:

## 1. REGISTRATION

To qualify for the warranties detailed in this Policy, Diono instructs all Purchasers to complete the online Product Registration form and mail the owner registration card included in the Product Purchase to Diono within (30) days of purchase. Failing to take such actions may prevent a Purchaser from qualify for the warranties detailed in this Policy. For more information about Product registration, Purchasers are recommended to refer to their Product's Product Manual, the Diono Instruction Manual, and/or contact Diono as provided in Section 9 of this Policy. Such registration requirements detailed in this subsection of the Policy do not apply to warranties provided by Diono E.U. as detailed in Section 2.4 below.

## 2. GENERAL WARRANTY PERIOD

**2.1 General U.S. Warranty Period.** Diono U.S.A. warrants to Purchasers that its Products will be free from defects in material and workmanship for one (1) year from the date of original purchase (the U.S. Warranty Period). During the U.S. Warranty Period, Diono U.S.A. will, at its option, repair or replace a Product if it is found by Diono U.S.A. to be defective in material or workmanship.

**2.2 General Canadian Warranty Period.** Diono Canada warrants to Purchasers that its Products will be free from defects in material and workmanship for one (1) year from the date of original purchase (the Canadian Warranty Period). During the Canadian Warranty Period, Diono Canada will, at its option, repair or replace a Product if it is found by Diono Canada to be defective in material or workmanship.

**2.3 General U.K. Warranty Period.** Diono U.K. warrants to Purchasers that its Products will be free from defects in material and workmanship for one (1) year from the date of original purchase (the U.K. Warranty Period). During the U.K. Warranty Period, Diono U.K. will, at its option, repair or replace a Product if it is found by Diono U.K. to be defective in material or workmanship.

**2.4 General European Warranty Period.** Diono E.U. warrants to Purchaser that its Products are in conformity with their original contracts of sale (collectively, the Contracts), and notably will be free from defects in material and workmanship at the time the Products were delivered to Purchaser, for two (2) years from the date of original purchase (the European Warranty Period). The Products are presumed to be in conformity with the Contract if they are fit for the purposes for which products of the same type are normally used, or show the quality and performance which are normal in products of the same type and which Purchaser can reasonably expect, given the nature of the Products and taking into account any public statements on the specific characteristics of the goods made about them by Diono, particularly in advertising or on labelling. Purchaser must inform Diono E.U. of the Lack of Conformity within a period of two (2) months from the date on which Purchaser detected such lack of conformity discovery. There shall be deemed to not be a Lack of Conformity at the time the Contract was concluded when Purchaser was aware, or could not reasonably be unaware, of the Lack of Conformity. During the European Warranty Period, Diono E.U. will, at the Purchaser's option, repair or replace a Product free of charge, within a reasonable time and without any significant inconvenience to the Purchaser, if it is found by Diono E.U. to be defective in material or workmanship respectively, unless this is impossible or disproportionately burdensome. When repair or replacement of a Product are impossible or disproportionately burdensome, the Purchaser may request a refund of the Product or a reduction of its price in proportion to the degree of non-conformity of the said Product, otherwise in accordance with the Diono Return Policy.

# WARRANTY

## 3. IMPLIED WARRANTIES

Any implied warranties applied to a Product, including without limitation implied warranties of merchantability and fitness for a particular purpose, shall be limited to the duration and terms of the express written warranties detailed in this Policy. Such warranties give Purchasers specific legal rights, which vary from jurisdiction-to-jurisdiction. Some U.S. states and Canadian provinces do not allow limitations on how long an implied warranty lasts or the exclusion or limitation of incidental or consequential damages. As such, such implied warranty limitations may not apply. Notwithstanding, neither Diono, nor any retailer selling any Product, authorizes any person to create for it any other warranty, obligation, or liability in connection with any Product not otherwise detailed in this Policy.

## 4. WARRANTY LIMITATIONS

**4.1 Damage Limitations.** The warranties identified in this Policy do not cover: (a) any Product purchased from a non-authorized Diono retailer; (b) the effects of normal wear and tear on a Product; (c) damage arising from Product repairs or modifications carried out by a third party; (d) a Product's involvement in an accident; (e) dissatisfaction with a Product's fit, weight, functionality, color or style; (f) Product damage resulting from negligence, modification, improper installation, accident, transport damage, incorrect washing of covers, corrosion, rust, mold, insufficient maintenance, misuse or abuse ; or (g) any Product defect that originated from material or design supplied by the Purchaser.

**4.2 Remedy Limitations.** It is expressly agreed that Diono's obligations and a Purchaser's remedies under the limited warranties provided in this Policy are exclusive and are strictly limited to the repair or replacement of a Product unless as otherwise detailed in Section 2 of this Policy. Such limited warranties are also conditional upon strict compliance with the provisions of the Instruction Manual for the Product(s) in question. In no event will Diono or any of their authorized manufacturers or retailers be liable to a Purchaser for any damages, including without limitation incidental or consequential damages, arising out of a Purchaser's use or inability to use any Product.

**4.3 Other Requirements and Limitations.** The warranties detailed in this Policy: (a) are non-transferable by Purchaser; (b) are only valid when supplied with proof of purchase from an authorized retailer or the Website; and (c) are valid only in the original country of the Product's purchase.

## 5. USE OF OUTSIDE PARTS AND ACCESSORIES

The use of covers, inserts, toys, accessories, or tightening devices produced by parties other than Diono or its authorized manufacturers (collectively, Outside Products) in any Product is not approved by Diono. The use of any Outside Product in conjunction with a Product could cause the Product to fail U.S., Canadian, U.K., and/or European safety standards. As a result, use of any Outside Product with a Product automatically voids any warranties granted under this Policy.

## 6. RESERVED RIGHTS

Diono reserves the right to: (a) discontinue any Product; (b) change a Product's parts, fabrics, or design; (c) substitute a Product with a comparable model or Product; or (d) apply a divergent manufacturer's guarantee for a Product in any specific geographical region.



# WARRANTY

## 7. SHIPPING CHARGES

Shipping charges for the replacement of any Product pursuant to a warranty granted under this Policy will be Purchaser's sole responsibility. Diono will not be responsible for any delays or damage caused by the shipment of a replacement Product. More information about Diono's shipping policies can be found in the Diono Shipping Policy.

## 8. QUESTIONS

Should any Purchaser have issues concerning a warranty or this Policy, Diono recommends contacting Diono Customer Service at 855-463-4666 or [support@diono.zendesk.com](mailto:support@diono.zendesk.com) for help or assistance for the U.S.. For Canada, call 1-866-954-9786 or [support@diono.zendesk.ca](mailto:support@diono.zendesk.ca) for help or assistance.

diono®  
#MadeOfSeattle



© 2024 Diono® LLC | 14810 Puyallup Street E | Suite 200  
Sumner WA 98390 | United States  
United States: Diono.com | 1-855-463-4666

Made in China | Fabricado en China  
All rights reserved | Reservados todos los derechos  
revised/modifié/revisado 20240821